

An aerial night view of a city, likely Dubai, featuring a prominent skyscraper with a unique, curved top. The image is overlaid with numerous horizontal digital glitch lines in various colors (blue, green, red, purple) and light trails from traffic, creating a futuristic, high-tech aesthetic. The sky is dark with some clouds, and the city lights are vibrant and colorful.

LEADING PROVIDER OF POWER SYSTEM SOLUTIONS

CONTENTS



P02

OVERVIEW

P03

ARCHITECTURE

P04

FEATURES

P04

TYPICAL MEASURES

P05

TYPICAL APPLICATIONS
AND PROJECTS

P06

PRODUCTS

P06 Stability Control IED CSS-100BE

P08 Stability Control System Management Master Station

P10 Communication Interface Equipment

OVERVIEW

When a major power system disturbance occurs, protection and control actions are required to stop the power system degradation, restore the system to a normal state and minimize the impact of the disturbance. The present control actions are not designed for a fast-developing disturbance and may be too slow. Local protection systems are not able to consider the overall system, which may be affected by the disturbance. Stability control system also called System Integrity Protection Schemes (SIPS) is a wide area disturbance protection system using systemwide information and sending selected local information to a remote location to counteract propagation of the major disturbances in the power system.

The stability control system is an advanced framework driven by the need to supervise critical nodes that heavily influence power system performance. It functions through automated measures, such as load shedding in specific areas or reducing generation output, to prevent instability and interconnection overloads that could otherwise compromise grid stability.

Three Lines of Defense in the Power Grid

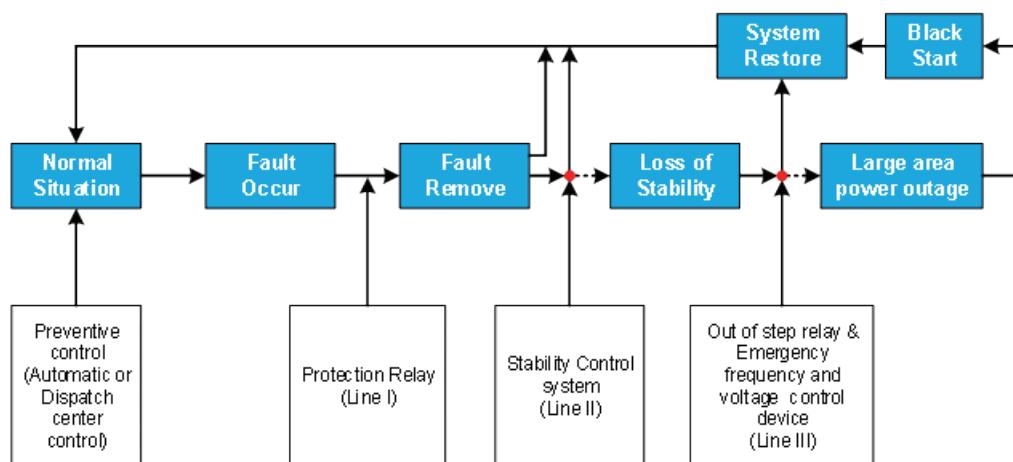

First Line – Relay Protection

Quickly detects faults and isolates the faulty equipment to stop fault propagation.

Second Line – Safety and Stability Control

Uses stability control devices (e.g., load shedding, generator tripping, system separation) to prevent system instability or collapse after severe disturbances.

Third Line – Emergency Control and Restoration

Applies emergency actions and black-start procedures to restore power after major outages.

ARCHITECTURE

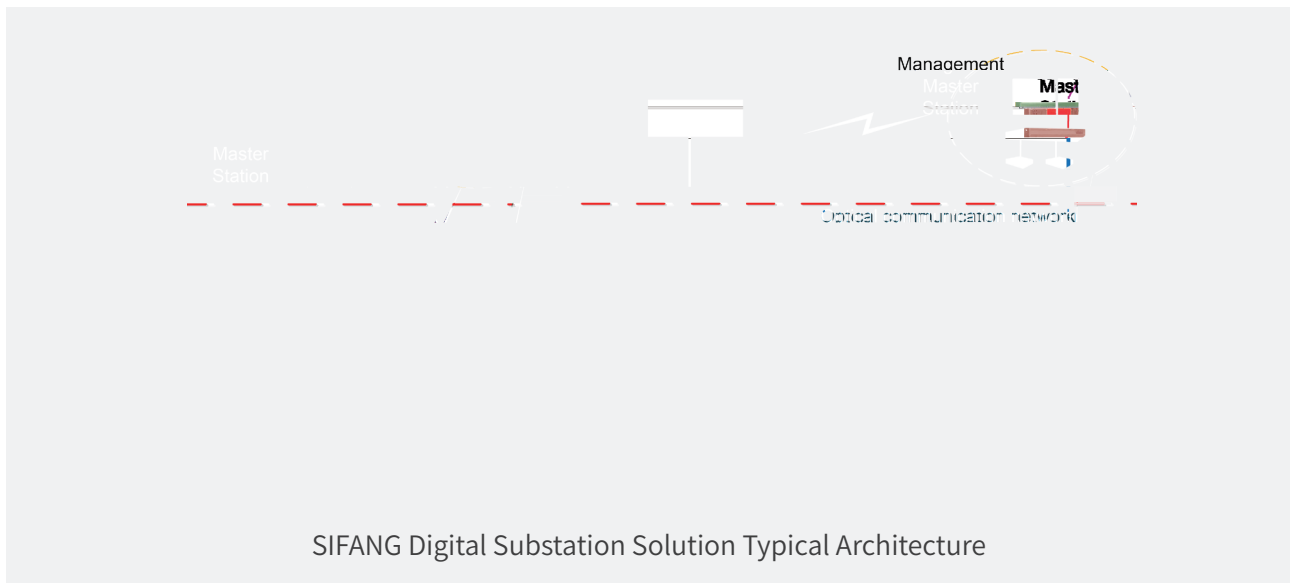

Designed with a three-tier architecture, the system leverages fiber-optic interconnections for multi-station coordination. The primary functional units are the Stability Control IEDs, which provide comprehensive system monitoring and command execution. These IEDs are versatile, functioning as Master, Slave, or Execution stations based on the network topology.

Master Station

- Stability control tables
- Collects information and Issues control commands to the execution station

Slave Station

- With partial stability control function for regional areas
- Collects information and commands and transmit them to the master station

Execution Station

- Receive and execute the operating command from the slave station

Management Master Station

- Collect all the operation information
- Realize on-line monitoring and centralized management of the stability control system
- Realize advanced functions

FEATURES

Wide-Area Protection and Control

By monitoring and analyzing the wide-area grid in real time, the stability control system devises and applies more effective strategies than traditional load - shedding protection for handling complex faults.

Precise and Rapid Control

Real-time monitoring enables precise control of targeted elements, avoiding over-shedding and delays, and executes actions within 200ms for faster, more accurate response.

Multi-Method Protection and Control

The system supports flexible combinations of generator tripping, load shedding, system separation, and power regulation to meet grid requirements.

Regulation Replaces Tripping

Compare to tripping the generation units directly, The stability control system can regulate the output of the generation to precisely regulate the system and maximize the profits of the generation.

TYPICAL MEASURES

Load Shedding

Automatically disconnects selected loads to rebalance power demand and generation, preventing frequency collapse or voltage instability. This is one of the most widely applied and effective SIPS measures, particularly for underfrequency and overload conditions.

Generator Tripping

Rapidly trips selected generating units to reduce excess power injection, mitigating overfrequency, especially following major contingencies such as transmission line outages.

System Separation

Intentionally divides the power system into electrically independent islands or splits buses to isolate unstable areas, thereby limiting disturbance propagation while maintaining service in unaffected sections.

Reactive Power Compensation

Automatically switches capacitor banks, reactors, or adjusts FACTS devices (e.g. SVC, STATCOM) to regulate voltage and enhance voltage and transient stability during stressed system conditions.

Adaptive Load and Generation Mitigation

Implements measurement-based, adaptive control actions that dynamically adjust load shedding or generation reduction according to real-time system conditions, rather than relying solely on fixed tripping thresholds.

TYPICAL APPLICATIONS AND PROJECTS

Application I — Power-Grid System Protection Northeast Power Grid High-Frequency Centralized Control Project

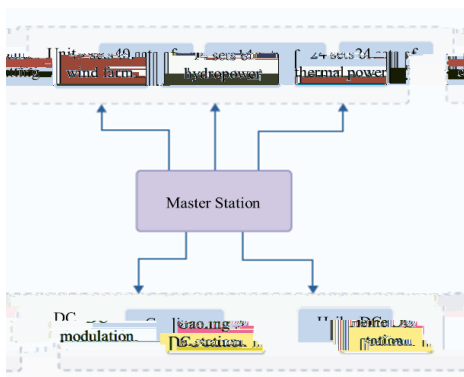

1 master station and 89 remote execution stations implementing DC modulation and selective generation tripping. Provides a high-reliability defense against severe AC/DC faults and effectively prevents cascading failures.

Application II — Renewable Energy Integration Terra PV and Energy Storage Project, the Philippines (3.5 GW PV + 4.5 GWh BESS)

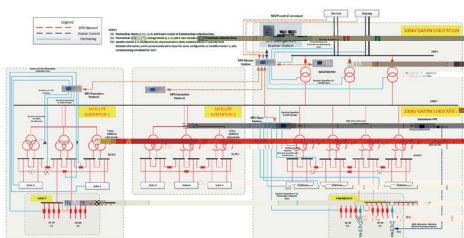

The stability control system maintains both local and system-wide stability for large-scale, decentralized, and intermittent renewable generation, effectively preventing overloads and instability following simultaneous transmission line outages. When grid faults occur, the system enables renewable energy plants to rapidly reduce their output, thereby enhancing overall system stability. In addition, the stability control device minimizes unnecessary unit tripping at renewable energy plants, helping to preserve their operational efficiency and economic benefits.

Application III — Enterprise Local Power Grid Control Indonesia OB Island Lygend Ferronickel Plant Isolated Grid Project



Equipped with 4*150MW generators for an annual 120kt ferronickel output, the project operates on an isolated grid. Integration of the SIFANG Stability Control System balances supply and demand, ensuring the system remains operational during faults and safeguarding the stability of the large-scale islanded network.

PRODUCTS

STABILITY CONTROL IED CSS-100BE

Overview



The CSS-100BE Safety and Stability Control IED developed by SIFANG integrates local measurement, decision-making, control, and remote communication functions into a single platform. It can be deployed to form a security and stability control system for regional or nationally interconnected power grids, and it is also suitable for safety and stability control of an individual power station.

The device can operate in both master and slave modes.

The master device is responsible for power grid operation mode identification, control strategy processing, information collection and evaluation, as well as communication and information exchange with other plants, substations, and slave devices. It issues coordinated control commands to the slave devices based on system conditions.

The slave device performs data acquisition and judgment, communicates with the master device, reports local information, and executes control commands issued by the master.

The CSS-100BE supports comprehensive safety and stability emergency control measures, including generator tripping, load shedding, system splitting (islanding), HVDC power emergency control, and fast reduction of generator output.

Both master and slave configurations support up to 36 analog inputs (three-phase current and voltage of up to six elements, or single-phase current and voltage of up to eighteen elements), no fewer than 48 binary inputs, and 32 binary outputs, providing sufficient capacity for complex stability control applications.

Technical Specifications

Power consumption	DC power circuit	35W when normal operation 60W when the protection acts	
	AC current circuit	1VA when $I_n=5A$ 0.5VA/phase when $I_n=1A$	
	AC voltage circuit	0.5VA/phase	
Measurement accuracy	AC voltage	$\pm 0.5\%$ (1V ~ 120V)	
	AC current	$\pm 1\%$ (0.04 ~ 20In)	
	Frequency	$\pm 0.01Hz$	
	Current	$\pm 5\%$	
Action value accuracy	Voltage	$\pm 3\%$	
	Frequency	$\pm 0.02Hz$	
	Time	$\pm 20ms$	
Action time	Abrupt-change value under fault condition (including current and power sudden)	Startup time: $5R \pm 3\%$	time /
	Line fault trip award time		
	Line fault-free trip award time		
	Device whole group action time		
	Remote command transmission time	$t \quad / \quad /$	

m ar sud°

timec



Stability Control System Management Master Station

This system serves not only as an operation and management platform for stability control devices, but also as an information support and auxiliary analysis system during power grid disturbances.

Main Functions

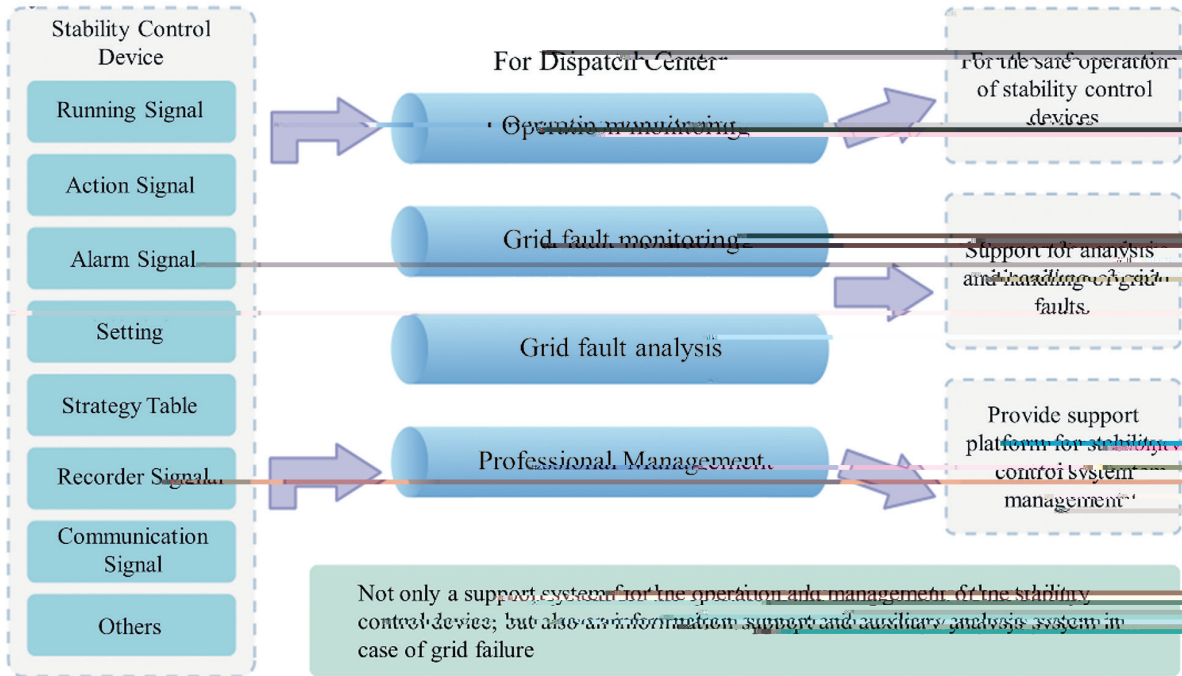

The SIFANG Stability Control Management System can integrate stability control devices from different manufacturers and models through two access modes, enabling centralized monitoring and management at the dispatching center:

Mode 1 – Direct Access

Stability control devices communicate directly with the stability control management master station using IEC 60870-5-103 or IEC 61850 protocols.

Mode 2 – SCADA Gateway Access

Stability control devices connect to the substation SCADA system via IEC 60870-5-103 or other supported protocols, and then communicate with the stability control management master station through the SCADA gateway.



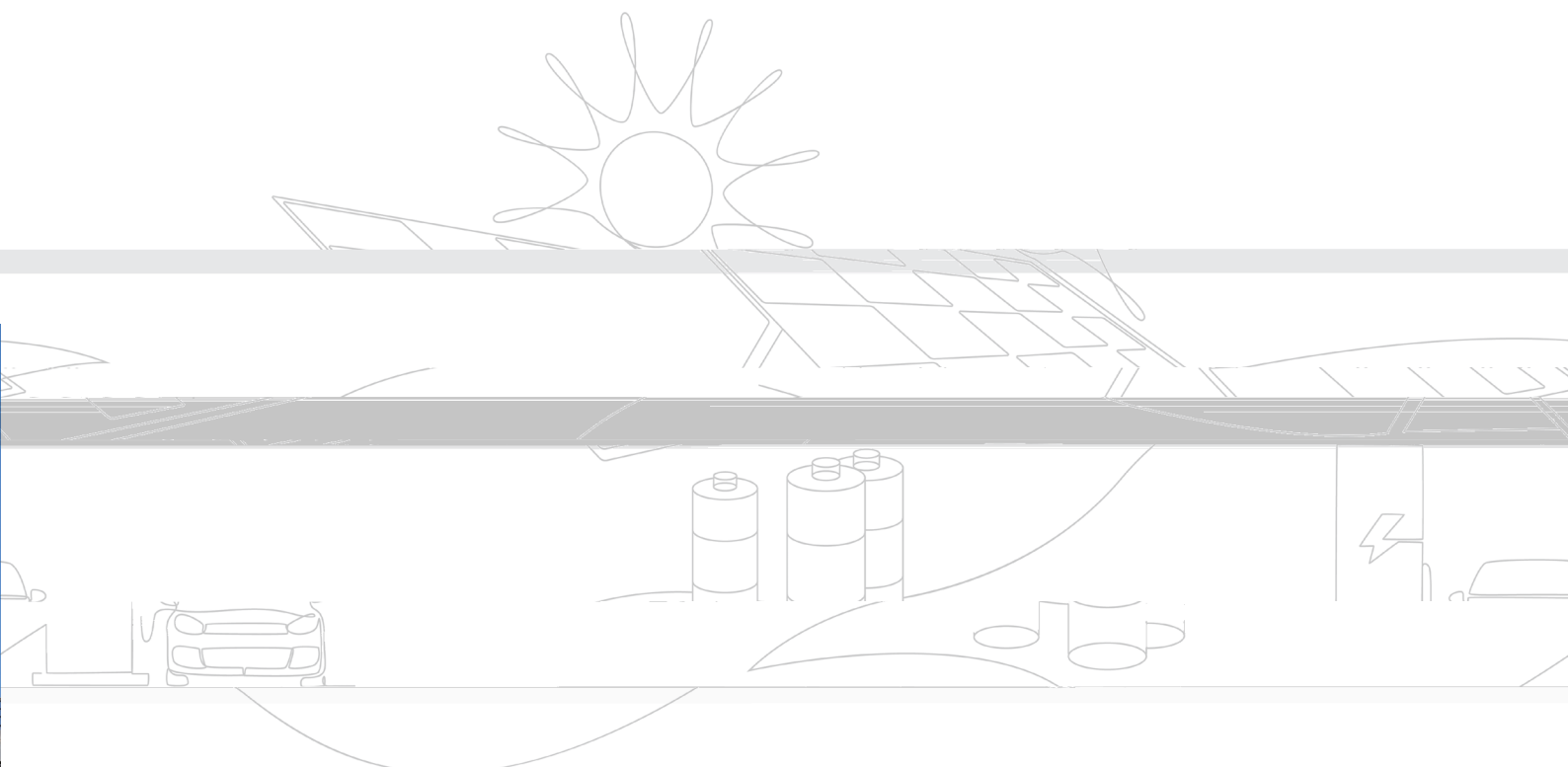
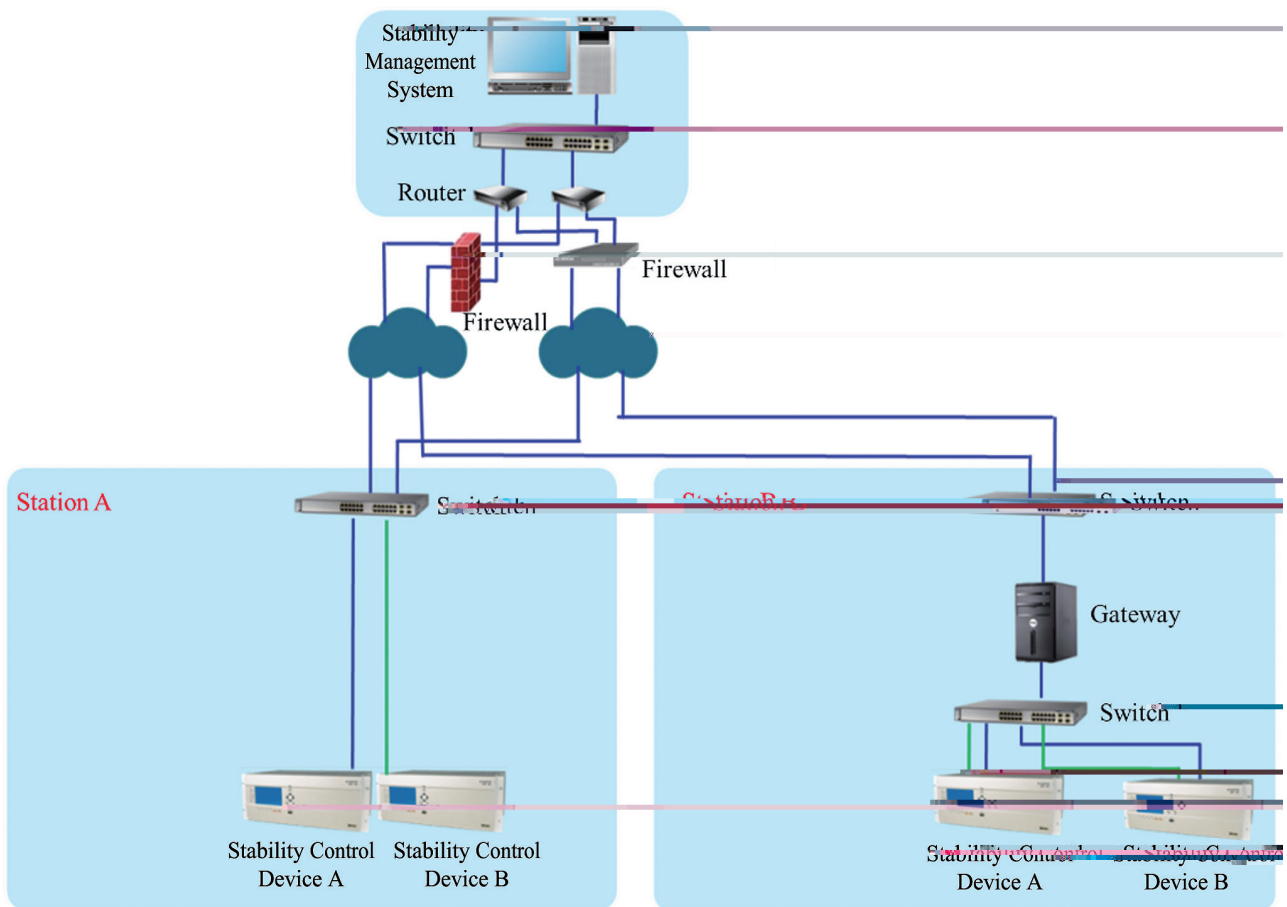

Communication Interface Equipment

For different application scenarios such as regional stability control, system protection and precise load shedding, a variety of communication interface devices can be selected.

CSC-187C Power System Communication Interface Device

Application Scenario

- Support up to 32 remote stations (a single stability control device can be equipped with 4 sets of CSC-187C to realize simultaneous communication with remote stations up to 32).

Technical Parameter

- 1U, 19 inches; DC220/100/48V power supply
- Up to 8 of communication interface, dedicated/multiplexed optical fiber communication
- Adopt the special 1B4B coding and HDLC protocol for stable control, compatible with 512kbps and 2Mbps transmission rate

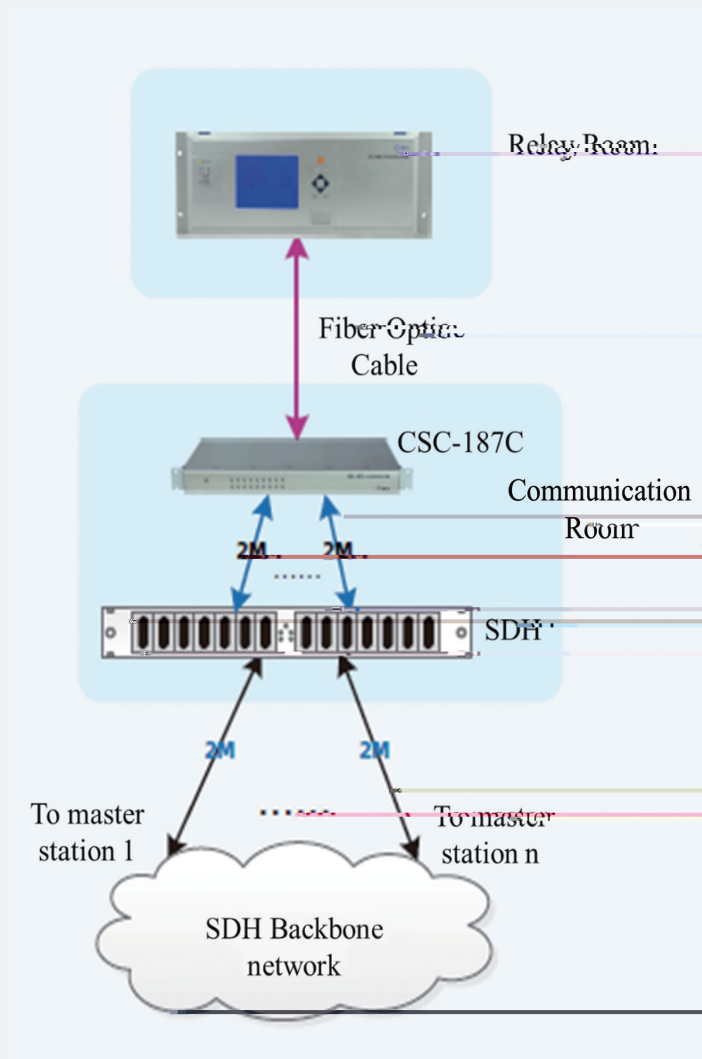

CSD-188A Communication Interface Device

Application Scenario

- Support more than 32 remote stations. (A single stability control device can be equipped with 4 such devices to realize simultaneous communication with remote stations up to 196)

Technical Parameter

- 4U, 19 inches; DC220/100/48V power supply
- Up to 49 of 2M communication interface, dedicated/multiplexed optical fiber communication
- Square channel simultaneous communication
- Adopt the special 1B4B coding and HDLC protocol for stable control, compatible with 512kbps and 2Mbps transmission rate

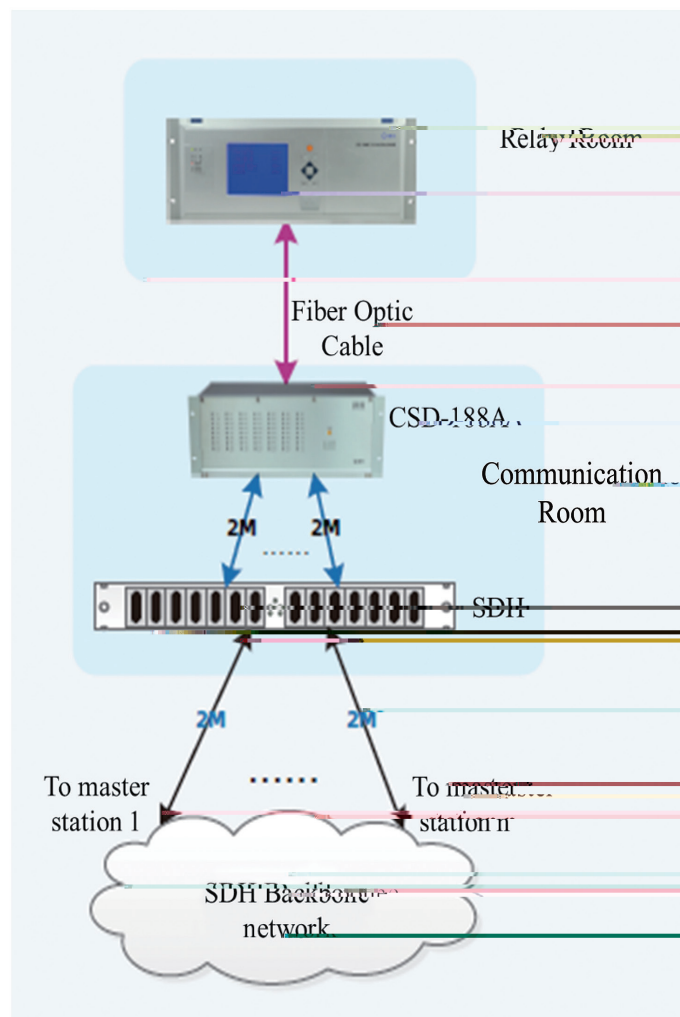

Stock Code
601126



BEIJING SIFANG AUTOMATION CO., LTD.

Add: No.9, Shangdi 4th Street, Haidian District, Beijing, P.R.China 100085

Tel: +86 10 62961515 | Fax: +86 10 62981004

Email: sf_sales@sf-auto.com

www.sifang-electric.com